

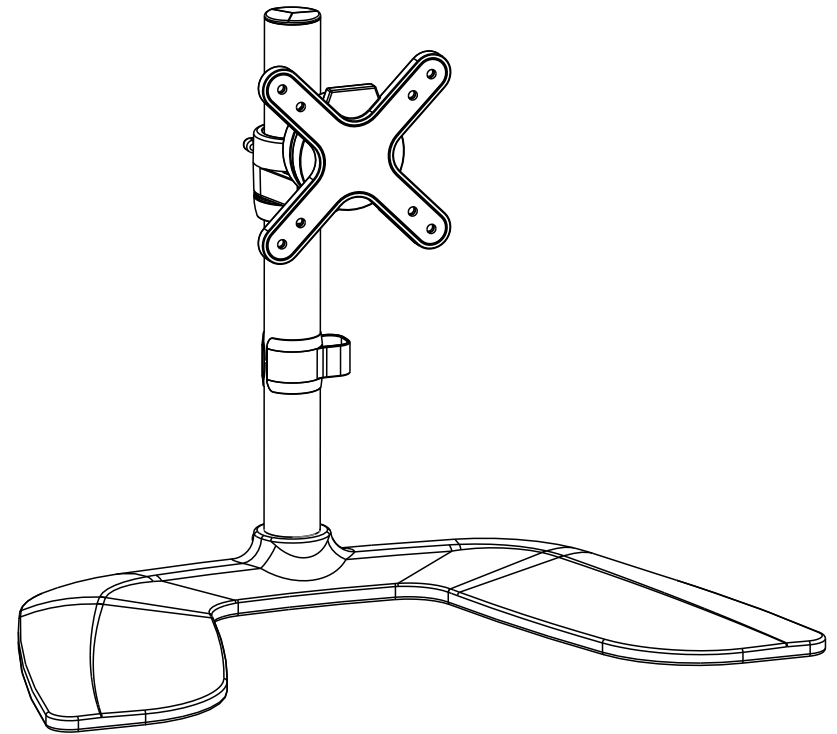



Monitor Table Stand



CAUTION: DO NOT EXCEED RATED LISTED WEIGHT. SERIOUS INJURY OR PROPERTY DAMAGE MAY OCCUR!

AS01T01	 75x75 100x100	 27" MAX	 8kg (17.6lbs) RATED
----------------	--	--	---

NOTE: Read the entire instruction manual before you start installation and assembly.

WARNING

- Do not begin the installation until you have read and understood all the instructions and warnings contained in this installation sheet. If you have any questions regarding any of the instructions or warnings, please contact your local distributor.
- This mounting bracket was designed to be installed and utilised **ONLY** as specified in this manual. Improper installation of this product may cause damage or serious injury.
- Make sure that the supporting surface will safely support the combined weight of the equipment and all attached hardware and components.
- Always use an assistant or mechanical lifting equipment to safely lift and position the equipment.
- Tighten screws firmly, but do not over tighten. Over tightening can cause damage to the items, This greatly reduces their holding power.
- This product is intended for indoor use only. Using this product outdoors could lead to product failure and personal injury.

Component Checklist

IMPORTANT: Ensure that you have received all parts according to the component checklist prior to installation. If any parts are missing or faulty, telephone your local distributor for a replacement.

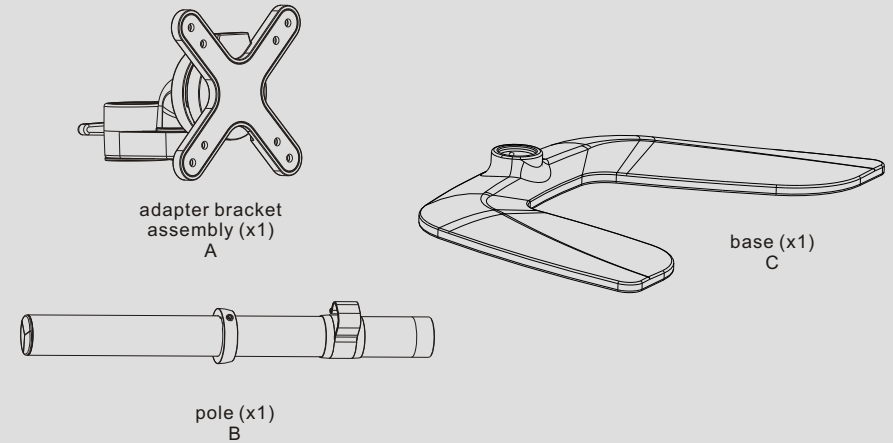

Package M



M4x14 (x4)
M-A



M5x14 (x4)
M-B



D5 washer (x4)
M-C

Package P



3mm Allen key (x1)
P-A



4mm Allen key (x1)
P-B

1. Separating the VESA Plate

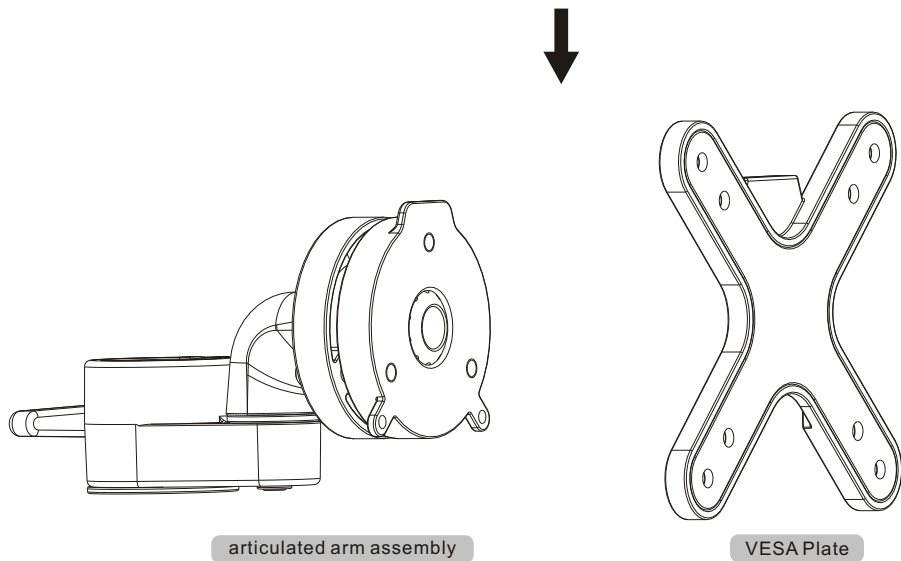
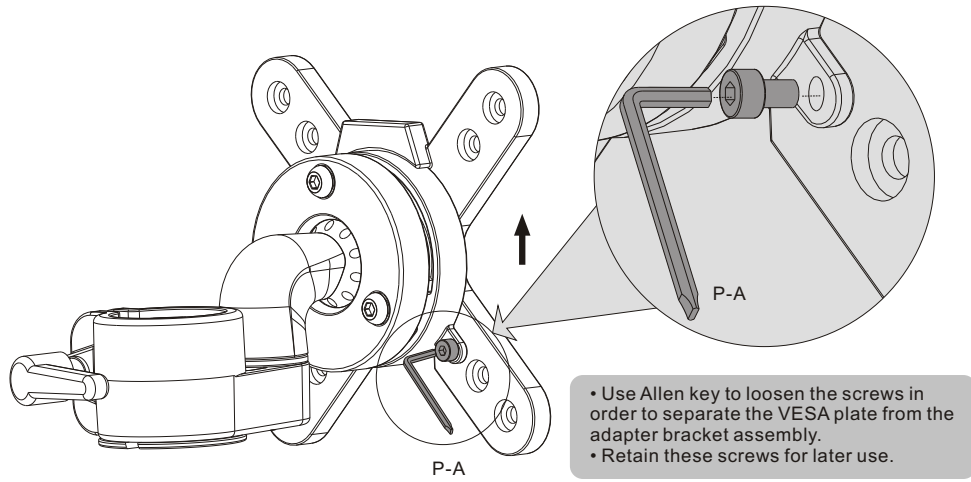

2. Assembling the Pole to Base

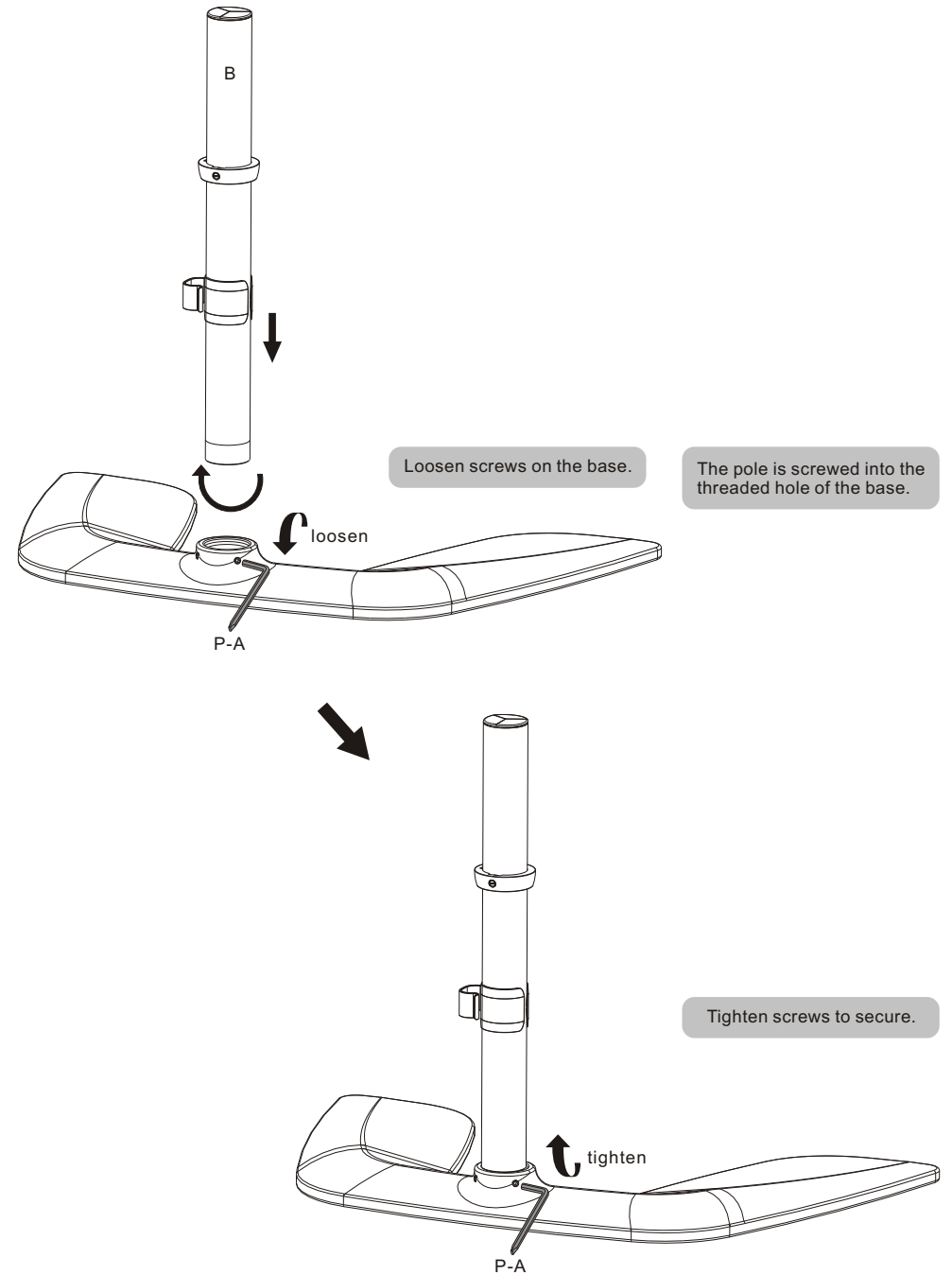

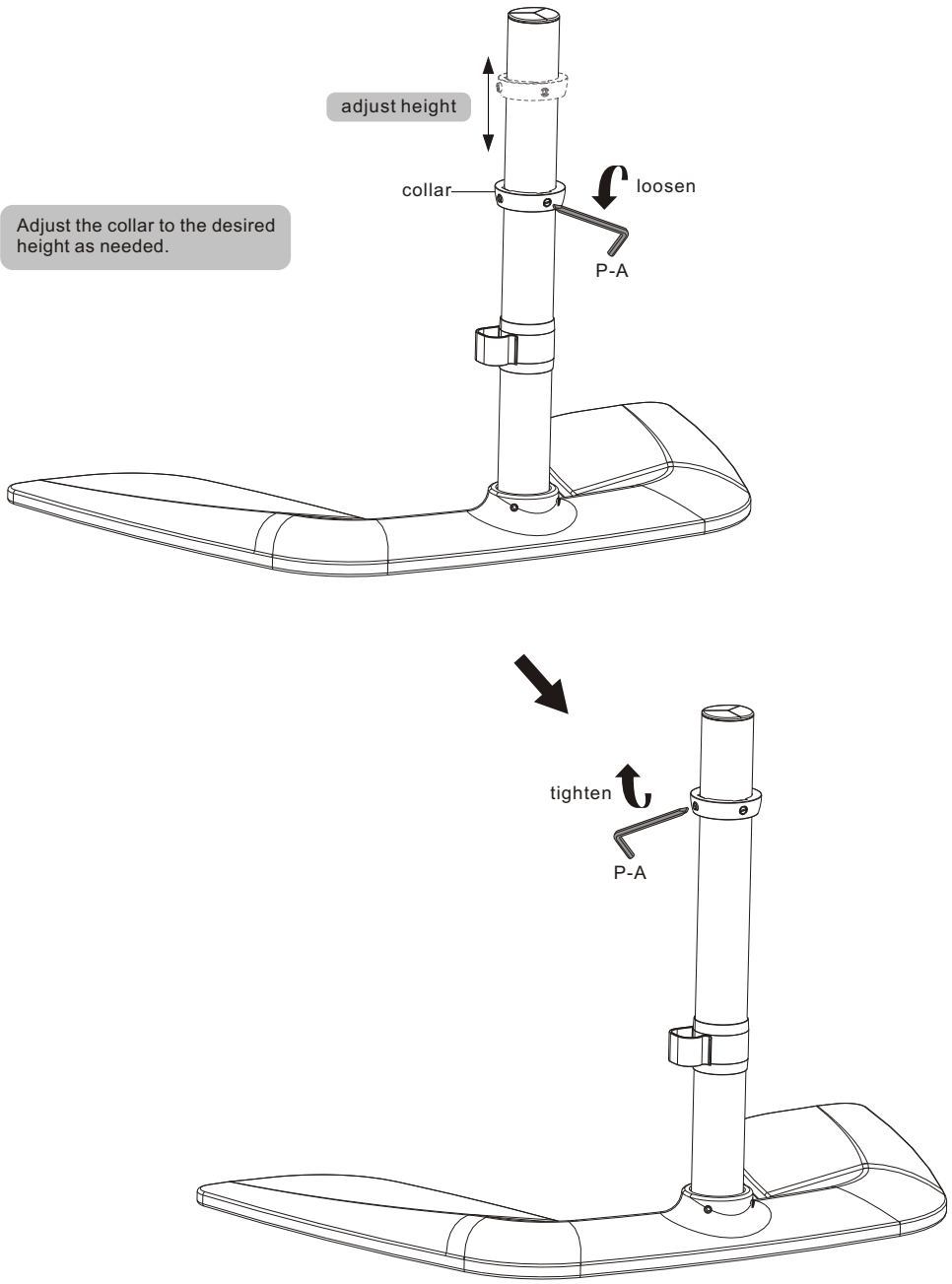

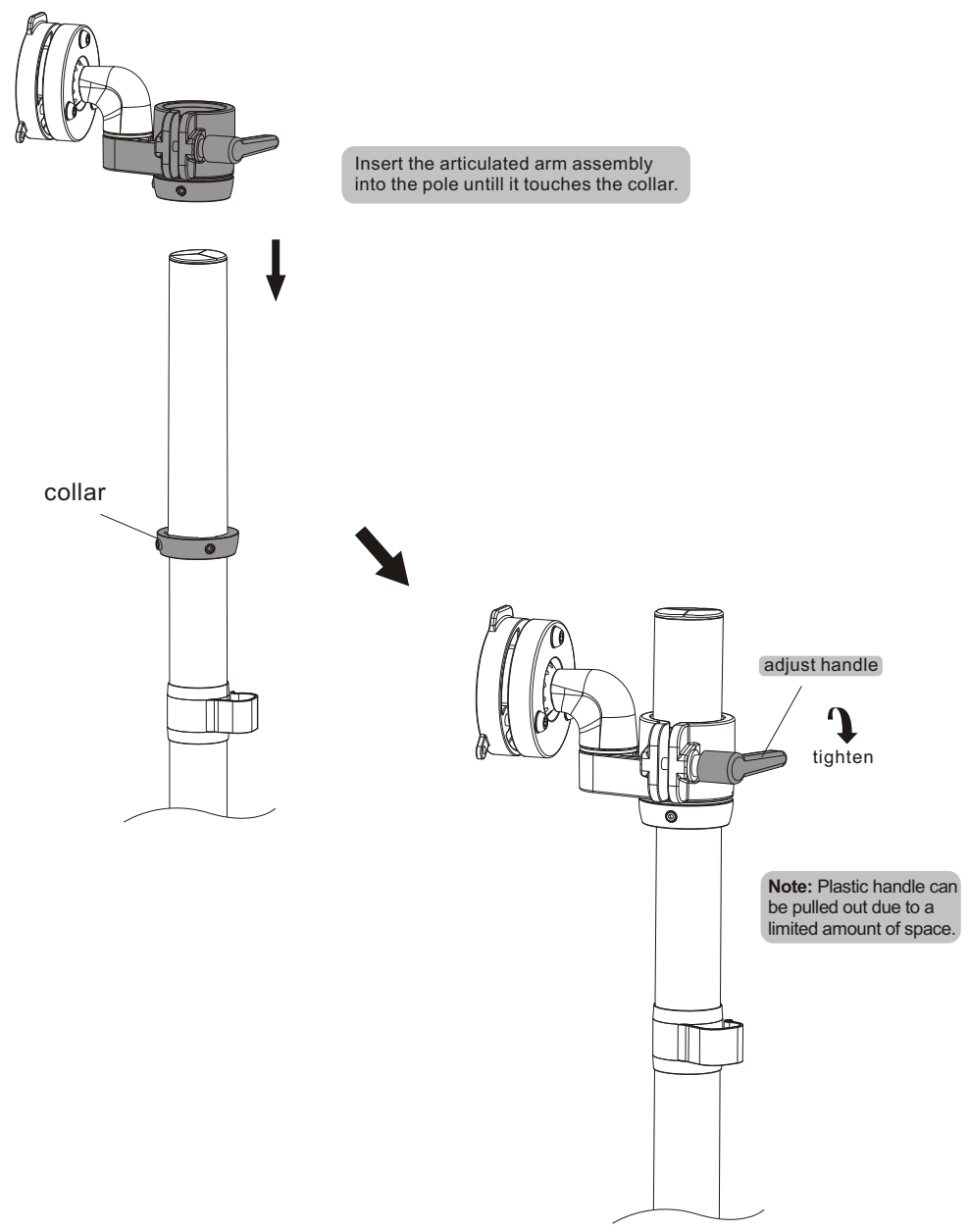

3. Installing the Articulated Arm Assembly

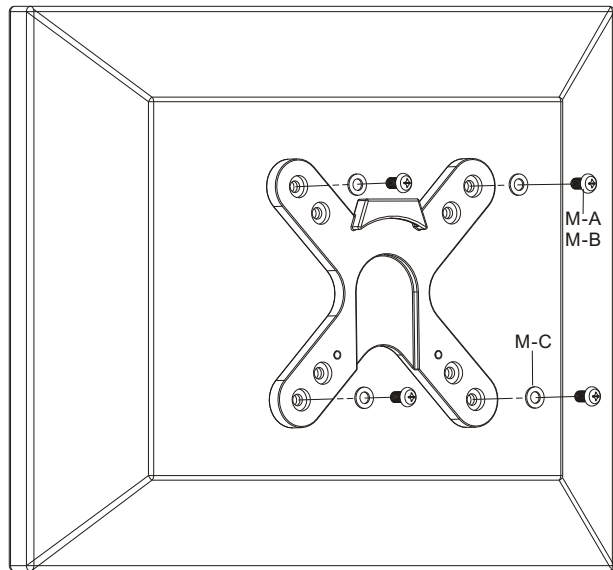
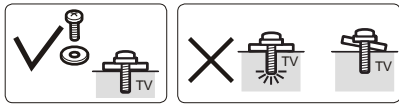
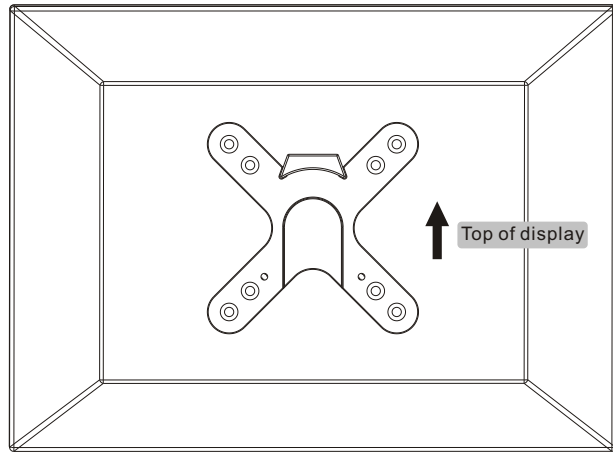

4. Installing the VESA Plate



Screw the VESA plate onto the display.

 **Tighten all screws but do not over tighten.**

5. Installing the Display

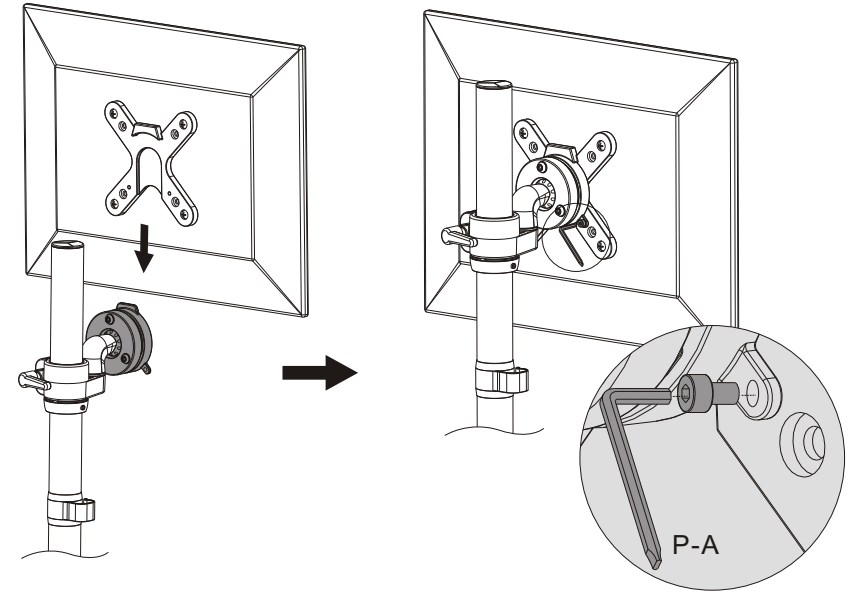

Insert the VESA plate onto the mount and use the previously removed screws to secure them. Make sure the display is safely secured before finally releasing.

6. Cable Management

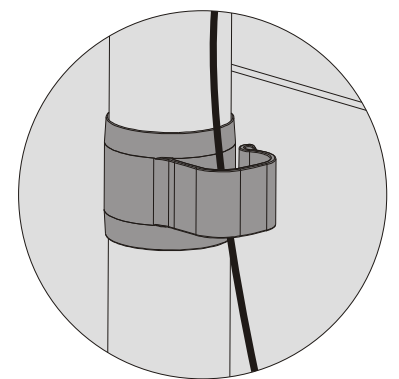
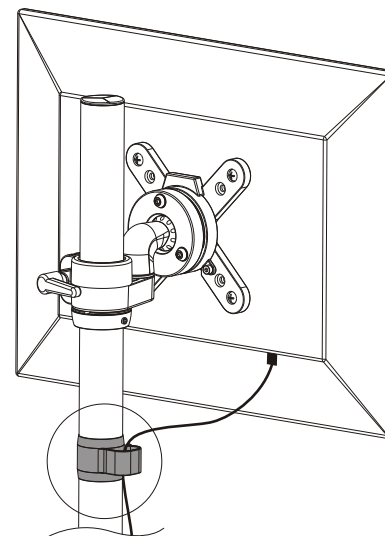

Use clips for routing the cables.

Note: Leave slack in the cable for arm movement.

7. Adjustment

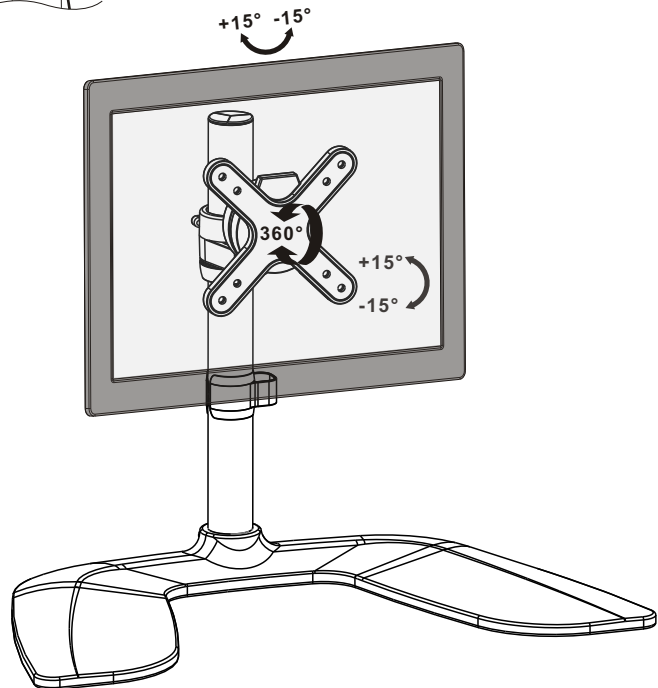
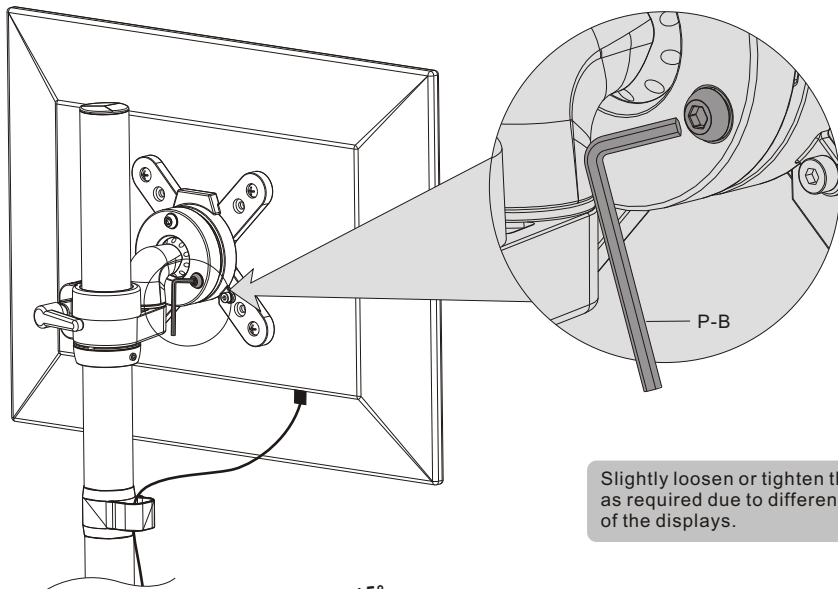

Adjust to the desired position or tilt.

Maintenance

- Check that the bracket is secure and safe to use at regular intervals(at least every three months).
- Please contact your distributor if you have any questions.